

Specifications

Models	GS-2669 RT		GS-3369 RT		GS-4069 RT	
Measurements	Metric	US	Metric	US	Metric	US
Working height maximum*	9.70 m	31 ft 3 in	11.75 m	38 ft	14.12 m	45 ft 9 in
A Platform height maximum	7.70 m	25 ft 3 in	9.75 m	32 ft	12.12 m	39 ft 9 in
Drive height	7.70 m	25 ft 3 in	9.75 m	32 ft	12.12 m	39 ft 9 in
B Platform height - stowed	1.47 m	4 ft 10 in	1.47 m	4 ft 10 in	1.65 m	5 ft 5 in
C Platform length - outside	2.79 m	9 ft 2 in	2.79 m	9 ft 2 in	2.79 m	9 ft 2 in
extended	4.32 m	14 ft 2 in	4.32 m	14 ft 2 in	4.32 m	14 ft 2 in
Slide-out platform extension deck	1.52 m	5 ft	1.52 m	5 ft	1.52 m	5 ft
D Platform width - outside	1.60 m	5 ft 3 in	1.60 m	5 ft 3 in	1.60 m	5 ft 3 in
Toeboard height	0.15 m	6 in	0.15 m	6 in	0.15 m	6 in
E Height - stowed**	2.59 m	8 ft 6 in	2.59 m	8 ft 6 in	2.74 m	9 ft
rails lowered	1.92 m	6 ft 3.5 in	1.92 m	6 ft 3.5 in	2.08 m	6 ft 10 in
F Length - stowed	3.76 m	12 ft 4 in	3.76 m	12 ft 4 in	3.76 m	12 ft 4 in
platform extended	4.81 m	15 ft 9.5 in	4.81 m	15 ft 9.5 in	4.81 m	15 ft 9.5 in
with outriggers	3.76 m	12 ft 4 in	3.76 m	12 ft 4 in	3.76 m	12 ft 4 in
G Width	1.75 m	5 ft 9 in	1.75 m	5 ft 9 in	1.75 m	5 ft 9 in
H Wheelbase	2.29 m	7 ft 6 in	2.29 m	7 ft 6 in	2.29 m	7 ft 6 in
I Ground clearance - center	0.24 m	9.5 in	0.24 m	9.5 in	0.24 m	9.5 in

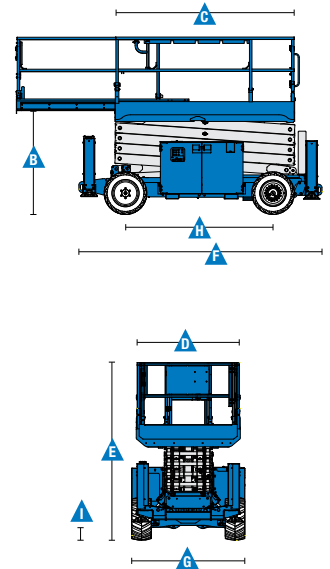

Productivity

Maximum platform occupancy***	4		4		3	
Lift capacity	680 kg	1,500 lbs	454 kg	1,000 lbs	363 kg	800 lbs
Extension deck capacity	136 kg	300 lbs	136 kg	300 lbs	136 kg	300 lbs
Drive speed - stowed	5.6 km/h	3.5 mph	5.6 km/h	3.5 mph	5.6 km/h	3.5 mph
Drive speed - raised	0.5 km/h	0.3 mph	0.5 km/h	0.3 mph	0.5 km/h	0.3 mph
Gradeability - stowed****	35%		30%		30%	
Maximum outrigger leveling:						
front/back uphill			5.3°/ 4.2°			
side to side			11.7°			
Turning radius - inside	2.11 m	83 in	2.11 m	83 in	2.11 m	83 in
Turning radius - outside	4.6 m	181.2 in	4.6 m	181.2 in	4.6 m	181.2 in
Raise/lower speed	36/33 sec		42/28 sec		69/46 sec	
Controls			proportional			
Drive			four wheel			
Tyres - rough terrain	30x66 cm	12x26 in	30x66 cm	12x26 in	30x66 cm	12x26 in

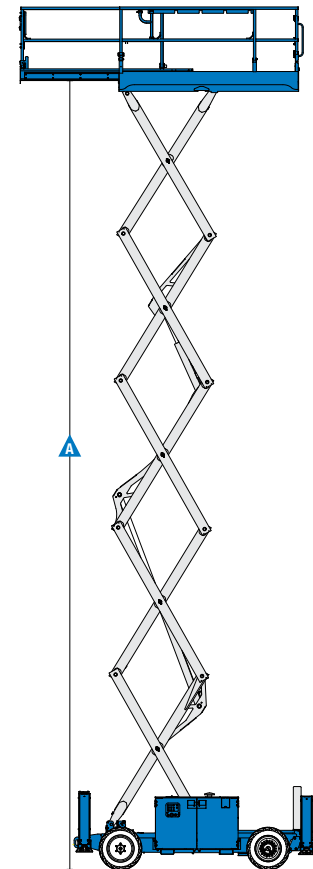

Power

Power source	Kubota D-1105 Diesel 24.8 hp					
Fuel tank capacity	37.9 L	10 gal	37.9 L	10 gal	37.9 L	10 gal
Hydraulic system capacity	68.1 L	18 gal	68.1 L	18 gal	68.1 L	18 gal

Weight*****

	3,739 kg	8,243 lbs	3,921 kg	8,643 lbs	5,078 kg	11,193 lbs
--	----------	-----------	----------	-----------	----------	------------

Standards Compliance

ANSI A92.6, CSA B354.2, CE Compliance, AS 1418.10

* The metric equivalent of working height adds 2 m to platform height. U.S. Adds 6 ft to platform height.

*** CE/AUS markets: GS™-3369 and GS™-4069 are limited to 2 person platform occupancy when used outdoors.

**** Gradeability applies to driving on slopes. Gradeability may vary depending on the weight of options installed on machine. See operator's manual for details regarding slope ratings.

***** Weight varies depending on options and country standards.

Self-Propelled Scissor Lifts

GS™ -2669 RT, GS-3369 RT, GS-4069 RT

Features

Standard Features

Measurements

GS-2669 RT

- 9.70 m (31 ft 3 in) working height
- Up to 680 kg (1,500 lbs) lift capacity

GS-3369 RT

- 11.75 m (38 ft) working height
- Up to 454 kg (1,000 lbs) lift capacity

GS-4069 RT

- 14.12 m (45 ft 9 in) working height
- Up to 363 kg (800 lbs) lift capacity

Productivity

- 2.79 x 1.6 m (110 x 63 in) steel frame platform with replaceable aluminum deck
- 1.52 m (5 ft) extension deck
- Automatic leveling hydraulic outriggers
- Folding guardrails
- Proportional lift and drive
- Full height swing gate
- 4WD
- Front oscillating axle
- Positive traction control
- Four-wheel braking
- Swing-out engine tray
- Non-marking foam-filled rough terrain tyres (eco fill)
- Tilt level sensor with audible alarm
- Descent alarm
- Horn
- Hour meter
- Dual flashing beacons
- Platform overload system
- Motion alarm
- Hydraulic oil cooler

Power

- Kubota Diesel 18.5 kW (24.8 hp)

Options & Accessories

Productivity

- Air line to platform
- Platform work lights

Power Options

- Cold weather package
- 240 Volt power to platform
- 7 kVA Hydraulic generator (240 V / 50 Hz)



Genie Australia – Toll free number 1800 788 633

Brisbane
HEAD OFFICE

33 Kimberley Street
Darra QLD 4076

Sydney

74 Glendenning Road
Glendenning NSW 2761

Melbourne

374 Hammond Road
Dandenong VIC 3175

Adelaide

16-18 Nixon Road
Wingfield SA 5013

Perth

126 Sheffield Road
Welshpool WA 6106

Genie United States | Distributed By:

18340 NE 76th Street
P.O. Box 97030
Redmond, Washington
98073-9730

Effective Date: June, 2013. Product specifications and prices are subject to change without notice or obligation. The photographs and/or drawings in this document are for illustrative purposes only. Refer to the appropriate Operator's Manual for instructions on the proper use of this equipment. Failure to follow the appropriate Operator's Manual when using our equipment or to otherwise act irresponsibly may result in serious injury or death. The only warranty applicable to our equipment is the standard written warranty applicable to the particular product and sale and we make no other warranty, express or implied. Products and services listed may be trademarks, service marks or trade names of Terex Corporation and/or their subsidiaries in the USA and many other countries. Genie is a registered trademark of Terex South Dakota, Inc. © 2013 Terex Corporation.