

## Type CK10 Concrete Kibble

Concrete Kibbles have been designed for easy transfer of concrete on site by overhead crane.

The type CK10 Concrete Kibble has a volume capacity of 1.0 cubic metres. This lightweight, yet heavy duty Kibble can be used for both bottom discharge or side discharge with the use of the adjustable chute. This unit is lever operated from either side, allowing flexible operation. The unit has been fitted with Forklift pockets for transport purposes about the work site. Also available in 0.5 & 0.75 cubic metre capacity units.

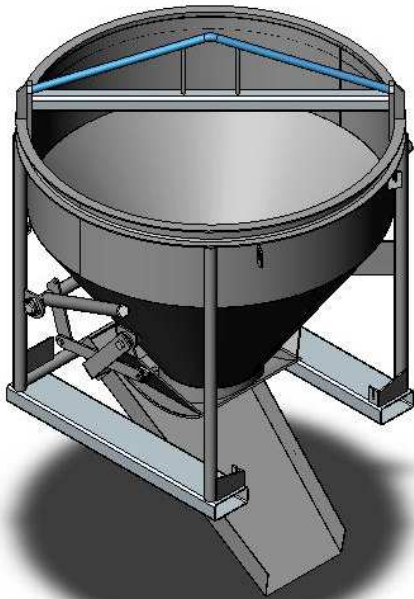

### SPECIFICATIONS:

- Safe Working Load (SWL) 3000kg
- Volume Capacity 1.0 cubic metres
- Unit Weight 320kg
- Fork Pocket Size 165 x 65mm
- Fork Pocket Centres 870mm
- Painted 'Safety Yellow' enamel

