

(D)	Originalbetriebsanleitung	3
(GB)	Original operating manual	11
(F)	Notice d'utilisation d'origine	18
(E)	Manual de instrucciones original	27
(I)	Istruzioni per l'uso originali	35
(NL)	Originele gebruiksaanwijzing	43
(S)	Originalbruksanvisning	51
(FIN)	Alkuperäiset käyttöohjeet	58
(DK)	Original brugsanvisning	66
(N)	Originalbruksanvisning	74
(P)	Manual de instruções original	82
(RUS)	Оригинал Руководства по эксплуатации	91
(CZ)	Originál návodu k obsluze	100
(PL)	Oryginalna instrukcja eksploatacji	108

RG 80 E

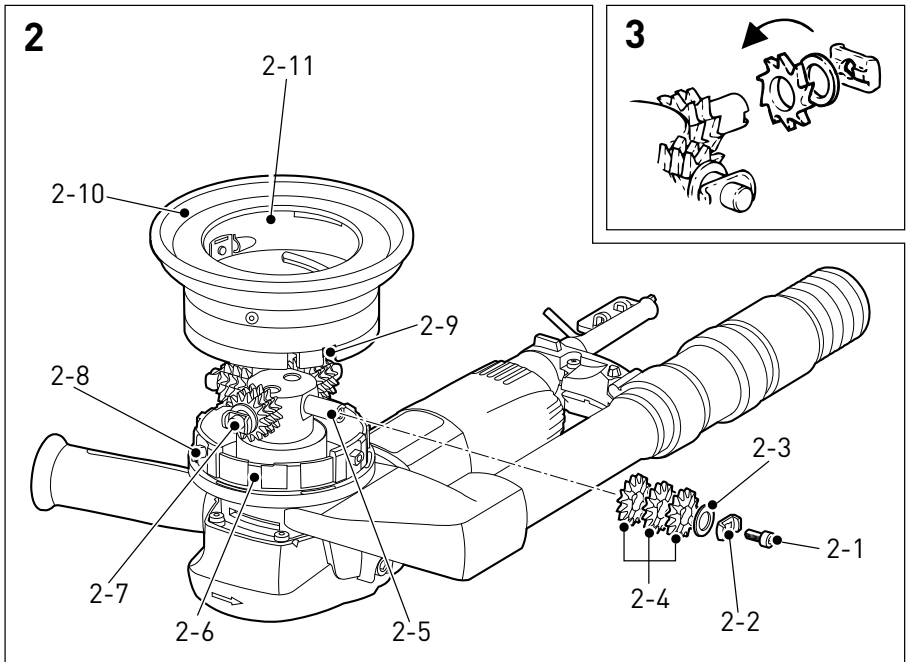

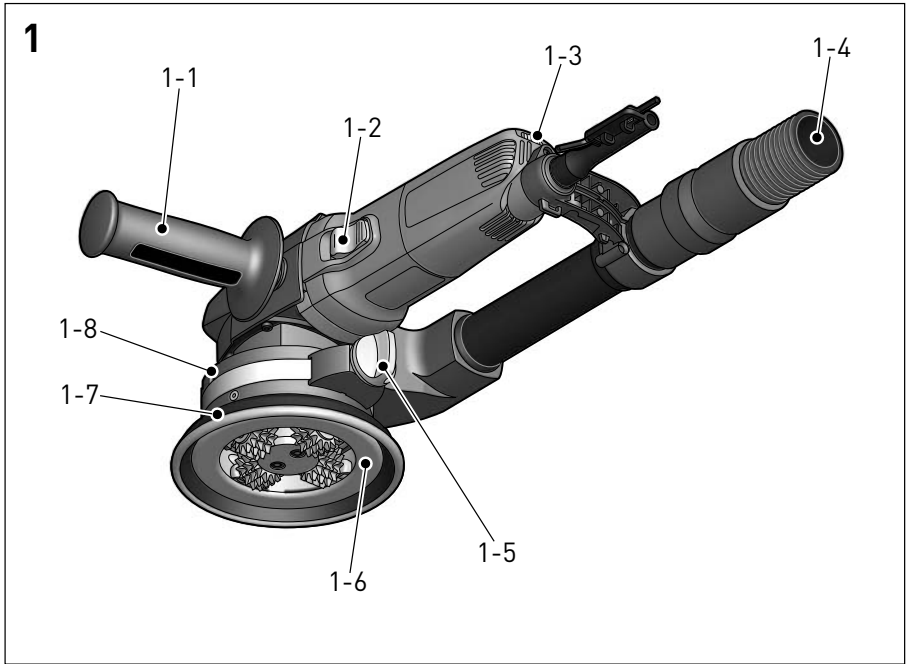

Renovation Cutter RG 80 E

1 Symbols



Double insulation



Warning of general danger



Risk of electric shock



Use protective goggles!



Wear ear protection!



Use protective gloves!



Read the instructions



Not to be included in municipal refuse

 Advice or tip

2 Technical data

Nominal voltage	220-240 V~
Mains frequency	50/60 Hz
Power input	1100 W
Adjustable revolutions	2000 – 5900 min ⁻¹
Tool diameter	80 mm
Weight	3.2 kg
Protection class	II / 

3 Prescribed usage

The machine works on the principle of an angle grinder but uses also special tools for milling and grinding, e.g. of concrete and plaster.

The machine is intended for removal of paint coats, plasters, residues of wall tile and carpet adhesives mainly from rigid surfaces. In addition, the machine can be used for roughing of flat concrete surfaces and for milling of lining work transitions.

The user proper is responsible for improper usage.

4 Control Elements

- [1-1] Additional handle
- [1-2] Switch lever
- [1-3] Adjusting wheel

- [1-4] Handle
- [1-5] Knob
- [1-6] Backstop bar
- [1-7] Suction flange
- [1-8] Scale
- [2-1] Bolt
- [2-2] Retainer
- [2-3] Washer
- [2-4] Milling rings
- [2-5] Tool carrier
- [2-6] Guide surface
- [2-7] Bolt
- [2-8] Sliding part
- [2-9] Slot
- [2-10] Suction flange
- [2-11] Guide surface

Accessories that are illustrated or described here are not always included in the scope of delivery.

The specified illustrations can be found at the beginning of the operating instructions.

5 Notes on Safety Prevention

5.1 General safety instructions

 **WARNING! Read all safety warnings and all instructions.** Failure to follow the warnings and instructions may result in electric shock, fire and/or serious injury.

Save all warnings and instructions for future reference.

The term „power tool“ in the warnings refers to your mains-operated (corded) power tool or battery-operated (cordless) power tool.

5.2 Safety instructions for all operations

Safety Warnings Common for grinding, surface grinding, grinding with wire brush or ABRASIV cutting:

- a) **This power tool is intended to function as a surface grinder or a cutter with a cutter head. Read all safety warnings, instructions, illustrations and specifications provided with this power tool.** Failure to follow all instructions listed below may result in electric shock, fire and/or serious injury.
- b) **Operations such as polishing or cutting are not recommended to be performed with this power tool.** Operations for which the power tool was not designed may create a hazard and cause personal injury.
- c) **Do not use accessories which are not specifically designed and recommended by the tool**

manufacturer. Just because the accessory can be attached to your power tool, it does not assure safe operation.

- d) **The rated speed of the accessory must be at least equal to the maximum speed marked on the power tool.** Accessories running faster than their rated speed can break and fly apart.
- e) **The outside diameter and the thickness of your accessory must be within the capacity rating of your power tool.** Incorrectly sized accessories cannot be adequately guarded or controlled.
- f) **The arbour size of wheels, flanges, backing pads or any other accessory must properly fit the spindle of the power tool.** Accessories with arbour holes that do not match the mounting hardware of the power tool will run out of balance, vibrate excessively and may cause loss of control.
- g) **Do not use a damaged accessory. Before each use inspect the accessory such as ABRASIV wheels for chips and cracks, backing pad for cracks, tear or excess wear, wire brush for loose or cracked wires. If power tool or accessory is dropped, inspect for damage or install an undamaged accessory. After inspecting and installing an accessory, position yourself and bystanders away from the plane of the rotating accessory and run the power tool at maximum no-load speed for one minute.** Damaged accessories will normally break apart during this test time.
- h) **Wear personal protective equipment. Depending on application, use face shield, safety goggles or safety glasses. As appropriate, wear dust mask, hearing protectors, gloves and workshop apron capable of stopping small ABRASIV or workpiece fragments.** The eye protection must be capable of stopping flying debris generated by various operations. The dust mask or respirator must be capable of filtrating particles generated by your operation. Prolonged exposure to high intensity noise may cause hearing loss.
- i) **Keep bystanders a safe distance away from work area. Anyone entering the work area must wear personal protective equipment.** Fragments of workpiece or of a broken accessory may fly away and cause injury beyond immediate area of operation.
- j) **Hold power tool by insulated gripping surfaces only, when performing an operation where the cutting accessory may contact hidden wiring**

or its own cord. Cutting accessory contacting a "live" wire may make exposed metal parts of the power tool "live" and shock the operator.

- k) **Position the cord clear of the spinning accessory.** If you lose control, the cord may be cut or snagged and your hand or arm may be pulled into the spinning accessory.
- l) **Never lay the power tool down until the accessory has come to a complete stop.** The spinning accessory may grab the surface and pull the power tool out of your control.
- m) **Do not run the power tool while carrying it at your side.** Accidental contact with the spinning accessory could snag your clothing, pulling the accessory into your body.
- n) **Regularly clean the power tool's air vents.** The motor's fan will draw the dust inside the housing and excessive accumulation of powdered metal may cause electrical hazards.
- o) **Do not operate the power tool near flammable materials.** Sparks could ignite these materials.
- p) **Do not use accessories that require liquid coolants.** Using water or other liquid coolants may result in electrocution or shock.

Further safety instructions for all operations

Kickback and Related Warnings

Kickback is a sudden reaction to a pinched or snagged rotating wheel, backing pad, brush or any other accessory. Pinching or snagging causes rapid stalling of the rotating accessory which in turn causes the uncontrolled power tool to be forced in the direction opposite of the accessory's rotation at the point of the binding.

For example, if an ABRASIV wheel is snagged or pinched by the workpiece, the edge of the wheel that is entering into the pinch point can dig into the surface of the material causing the wheel to climb out or kick out. The wheel may either jump toward or away from the operator, depending on direction of the wheel's movement at the point of pinching. ABRASIV wheels may also break under these conditions.

Kickback is the result of power tool misuse and/or incorrect operating procedures or conditions and can be avoided by taking proper precautions as given below.

- a) **Maintain a firm grip on the power tool and position your body and arm to allow you to resist kickback forces. Always use auxiliary handle, if provided, for maximum control over kickback or torque reaction during start-up.** The operator can control torque reactions or

- kickback forces, if proper precautions are taken.
- b) **Never place your hand near the rotating accessory.** Accessory may kickback over your hand.
 - c) **Do not position your body in the area where power tool will move if kickback occurs.** Kickback will propel the tool in direction opposite to the wheel's movement at the point of snagging.
 - d) **Use special care when working corners, sharp edges etc. Avoid bouncing and snagging the accessory.** Corners, sharp edges or bouncing have a tendency to snag the rotating accessory and cause loss of control or kickback.
 - e) **Do not attach a saw chain woodcarving blade or toothed saw blade.** Such blades create frequent kickback and loss of control.

Additional safety instructions for grinding and cutting

Safety Warnings Specific for Grinding and ABRASIV Cutting-Off Operations:

- a) **Use only wheel types that are recommended for your power tool and the specific guard designed for the selected wheel.** Wheels for which the power tool was not designed cannot be adequately guarded and are unsafe.
- b) **The guard must be securely attached to the power tool and positioned for maximum safety, so the least amount of wheel is exposed towards the operator.** The guard helps to protect operator from broken wheel fragments and accidental contact with wheel.
- c) **Wheels must be used only for recommended applications. For example: do not grind with the side of cut-off wheel.** ABRASIV cut-off wheels are intended for peripheral grinding, side forces applied to these wheels may cause them to shatter.
- d) **Always use undamaged wheel flanges that are of correct size and shape for your selected wheel.** Proper wheel flanges support the wheel thus reducing the possibility of wheel breakage. Flanges for cut-off wheels may be different from grinding wheel flanges.
- e) **Do not use worn down wheels from larger power tools.** Wheel intended for larger power tool is not suitable for the higher speed of a smaller tool and may burst.

Additional safety instructions for wire brushing operations

Safety Warnings Specific for Wire Brushing Operations:

- a) **Be aware that wire bristles are thrown by the brush even during ordinary operation. Do not overstress the wires by applying excessive load to the brush.** The wire bristles can easily penetrate light clothing and/or skin.
- b) **If the use of a guard is recommended for wire brushing, do not allow any interference of the wire wheel or brush with the guard.** Wire wheel or brush may expand in diameter due to work load and centrifugal forces.

Further safety instructions

- The machine may not be used in damp and wet spaces, outdoor when it is rainy, foggy or snowy or in the explosive environment.
- Before use always inspect the flexible lead and the plug. Have the defects repaired by a specialist repair shop.
- Outside the premise use only approved extension leads and cable connections.
- Apply the machine to the material only when switched on.
- Do not carry the machine by the lead.
- Do not work on a ladder.
- When operating the tool, use protective gloves and tough footwear.
- When operating the tool, use goggles and ear protectors.
- The dust generated during work is harmful to health. When operating the tool, use the dust extraction system and the respirator.
- Materials containing asbestos are not allowed to mill.
- Flexible power supply cable always route from the tool backwards.
- Only use milling rings recommended by the manufacturer.
- The machine is only allowed be used when protective guard is in place and additional handle is fastened.
- Plug in the flexible power supply cable's plug into the wall socket when the machine is off.
- Make yourself sure whether the material that is going to be machined does not contain electric, water or gas lines – an injury could occur.
- Do not mill over metal objects, nails or screws.

- The machine is not allowed to be operated by a person under 16 years of age.
- **Only for AS/NZS:** The tool shall always be supplied via residual current device with a rated residual current of 30 mA or less.

5.3 Emission levels

Measured values determined according to EN 60 745.

Typically the A-weighted noise level of the tool are:

Sound pressure level: 86 dB (A)

Sound power level: 97 dB (A)

Inaccuracy of measurement K = 1.5dB (A)



CAUTION

Operating noise

Damage to hearing

- ▶ Use ear protection!

Measured values determined according to EN 60 745.

Grinding with grinding wheel $a_v = 5.3 \text{ m/s}^2$

Inaccuracy of measurement K = 1.5 m/s^2

The specified emissions values (vibration, noise) – are used to compare machines.

– They are also used for making preliminary estimates regarding vibration and noise loads during operation.

– They represent the primary applications of the power tool.

Increase possible for other applications, with other insertion tools or if not maintained adequately. Take note of idling and downtimes of machine!

6 Activation



WARNING

Risk of accident if the machine is operated using unauthorised voltages or frequencies.

- ▶ The mains voltage and the frequency of the power source must correspond with the specifications on the machine's name plate.
- ▶ In North America, only Festool machines with the voltage specifications 120 V/60 Hz may be used.

6.1 Switching on – off

Switching on

Move the switch button [1-2] forward and the device will switch on. If you press the front part of the button, it will arrest and start continual operation.

Switching off

Press the rear part of the button [1-2] to relax arrest. The button returns to switched-off position.

6.2 Motor electronics

Starting current limitation

Electronically controlled continual running secures device acceleration without back thrust. Due to starting current limitation in the device, 15A protection is sufficient.



WARNING

Devices without starting current limitation need higher protection – at least 16A circuit breaker.

Switching off during back thrust

During sudden drop of revolutions, for example blocking in dividing cut, the current input in motor stops. For re-starting, the device must be first switched off and again switched on.

Protection against re-starting

Prevent uncontrolled starting of the device after current supply cut off. For re-starting, the device must be first switched off and again switched on.

Revolutions pre-setting

Use the revolutions regulator [1-3] for smooth revolutions pre-setting.

Degree 1: 2000 min^{-1} Degree 4: 4500 min^{-1}

Degree 2: 2950 min^{-1} Degree 5: 5300 min^{-1}

Degree 3: 3750 min^{-1} Degree 6: 5900 min^{-1}

Required number of revolutions depends on applied grinding wheel and worked material.

Constant electronics

Constant electronics maintains revolutions during operation and idle run near the constant. Regular operating shift is achieved.

Protection from overloading dependant on temperature

The safety electronics switches to cooling regime when the critical temperature is reached. Motor continues running at approximately 2500 min^{-1} revolutions, constant electronics is deactivated. After cooling to approximately 10 – 20 s, the device is fully operational.

Heat protection for devices heated during operation, reacts adequately sooner.

7 Milling tools

7.1 Choice of cutter and grinding head

According to use and type of application, there are various types of cutter heads. To achieve optimal work results, use suitable grinding heads.

Data in the Chart showing speed pre-selection options are recommended values only; practice testing should be always performed – see page 19!

7.2 Cutter/Grinding head change

Before putting into operation, check perfect run of the cutter tool: turn it manually.

Make sure that all screws are tightened up well.

Four screws connecting the flange and the head tool should be well-tightened up: use torque 5 Nm.

Two screws fixing the position of the head on the machine should be well-tightened up: use torque 8 Nm.

Do not leave any tools inserted in.

7.3 Replacing Grinding Wheels



WARNING

Risk of accident, electric shock

- ▶ Always pull the plug out of the socket before performing any type of work on the machine.

If teeth of milling rings that are made of hard alloy are worn, it is possible to replace them.

- ▶ By means of turning the knob [1-5] release the clamping belt to such extent so as it is possible to move the suction flange [1-7].
- ▶ Turn the suction flange fully counter-clockwise and pull it downwards.
- ▶ Release two bolts [2-1], [2-7] on four axes of tool carrier using the hexagonal spanner S4. Now, the milling cutters are easily accessible.
- ▶ When replacing milling rings replace also bolts [2-1], [2-7] and excessive turn retainers [2-2]. The bolts have been fixed by light adhesive agent so as they cannot be loosened by vibrations. Only use originally supplied bolts.
- ▶ Firstly, put three milling rings [2-4] onto each axis, then the washer [2-3]; fasten everything with the help of excessive turn retainer [2-2] and bolts [2-1], [2-7]. It is extremely important that you insert the excessive turn retainer into corresponding slot [2-5] located in tool carrier axis. If the excessive turn retainers are not installed, bolts could be loosened during operation; this may cause major losses.

- ▶ Put on the suction flange [2-10] so as sliding parts [2-8] snap into corresponding slots [2-9] located on suction flange.
- ▶ Set the milling depth required and tighten the clamping belt using the turning knob.

When installing the model with flat teeth, it is important that milling rings are installed as shown in the Fig. [3]; it means that tips must be oriented in the direction of milling head rotation.

The model with spiked teeth (HW-SZ 12) is used to remove old layers of paint from concrete or plasters. The version with flat teeth (HW-FZ 12) is used for smoothening of timbering gaps and for machining of concrete edges.

8 Operation



WARNING

When operating with renovation cutter, you must use goggles so as you protect your eyes from flying material particles!

Adjustable height of suction flange is necessary to be adapted to mode of use. When removing old layers of paints, tips of teeth would not overlap the suction flange by more than 1 mm. In the contrary, when milling plasters, the milling rings can overlap by 2 to 4 mm. To adjust the height, slightly release the clamping belt using the turning knob [1-5] and turn the suction flange [1-7] counter-clockwise or clockwise. Adjustable range is up to 5.5 mm. The milling depth adjusted can be roughly read on the scale [1-8]. If height adjustment does not operate smoothly, we recommend cleaning the guide surfaces [2-6] and [2-11]. Once the height is adjusted, fasten tight the clamping belt.



CAUTION

Do not ever operate the machine without suction flange! Only remove it when cleaning the guide surfaces or when replacing milling rings. When carrying out these operations, always remove the plug from wall socket!

The suction flange can be also used on machined area as a holder [1-6]. On principle, the renovation cutter should be applied flatwise onto the work piece. In case of flat surfaces, optimum adjustment is 6th step of the Electronic.



CAUTION

During work, inspect whether milling rings still freely rotate on axes. If it is not the case, e.g. due to accumulated dust; it is necessary to remove it from the milling head. For this reason the machine should not be operated without suction system connected!

8.1 Suction system

To ensure the operability of suction system, put the hose (36 mm diameter) of some Festool brand vacuum cleaner onto the handle adaptor [1-4]. Keep in mind that as filtration sack is being filled, the suction effectiveness significantly reduces. Also clean vacuum cleaner's filter time to time.



CAUTION

Always operate the machine with the suction system connected; otherwise, the milling rings as well as suction flange height adjustment system will be clogged with dust!

To prevent discharges of static electricity in dusty environment, use vacuum cleaners of antistatic models only.

8.2 Additional handle

To operate the grinder with both hands, it is possible to fasten an additional handle [1-1] to the left-hand side of gearbox cover's front part. The special "VIBRASTOP" design reduces vibrations in the additional handle.

9 Service and maintenance



WARNING

Risk of accident, electric shock

- ▶ Always pull the plug out of the socket before performing any type of work on the machine.
- ▶ All maintenance and repair work which requires the motor housing to be opened, must only be carried out by an authorised service workshop.

- Wrapped electric tools can be stored in a dry place without heating, with temperatures not lower than -5°C. Unwrapped electric tools can only be stored in dry places with temperatures not lower than +5°C, without sudden changes in the temperature.

- To ensure the airflow is sufficient, cooling openings of the motor must be always clean and free.
- The machine is equipped with special self-disconnecting brushes. When the brushes are worn, the power supply is automatically disconnected, and the machine is stopped.
- If the suction flange height adjustment system does not operate smoothly, the flange must be removed and cleaned.



Customer service and repair. Only through manufacturer or service workshops: Please find the nearest address at: www.festool.net/service



Use only original Festool spare parts! Order No. at: www.festool.net/service

10 Environment

Do not throw the power tool in your household waste! Dispose of the machine, accessories and packaging at an environmentally-responsible recycling centre! Observe the valid national regulations.

EU only: European Directive 2002/96/EC stipulate that used electric power tools must be collected separately and disposed of at an environmentally responsible recycling centre.

Information on REACH:

www.festool.com/reach

11 EU Declaration of Conformity

Renovation Cutter	Serial no.
RG 80 E	769231, 768829, 768798

Year of CE mark: 2013

We declare under sole responsibility that this product comply with all relevant requirements of the following directives, norms or normative documents:









2006/42/EC, 2004/108/EC, 2011/65/EU, EN 55 014-1, EN 55 014-2, EN 60 745-1, EN 60 745-2-3, EN 61 000-3-2, EN 61 000-3-3.

Festool Group GmbH & Co. KG

Wertstr. 20, D-73240 Wendlingen

ppa. Dr. Martin Zimmer

Dr. Martin Zimmer
Head of Research, Development and Technical Documentation
2013-04-15

Cutter head	Installation	Application	Electronic adjusting wheel
	Cutter head "Flat Shape" with 12 hard-metal cutter wheels FZ-RG 80	<ul style="list-style-type: none"> - Plaster removal - Removing of elastic protective coats on walls and flooring - Removing of foam base and glue remnants (carpet remnants) - Removing of floor tile glue remnants - Removing of bitumen and concrete protective coats - Removing of latex paints or oil paints on gypsum surface 	4-6
	Cutter head "Pointed Shape" with 12 hard-metal cutter wheels SZ-RG 80	<ul style="list-style-type: none"> - Plaster removal - Removing of bumps and excessive material after boarding – fresh concrete work - Removing of foam base and glue remnants (and carpet remnants) - Removing of floor tile glue remnants - Removing of plaster made of synthetic resin (made on thermal insulation) 	4-6
Grinding head	Installation	Application	Electronic adjusting wheel
	Diamond grinding head: grinding wheel with 8 segments provided with diamond grits DIA HARD-RG 80	<ul style="list-style-type: none"> - Removing of bumps and excessive material – screed floor cover - Grinding and cleaning weather-worn parts of concrete constructions - Removing of bumps – old concrete 	6
	Diamond grinding head: grinding wheel with 8 segments provided with diamond grits DIA ABRASIV-RG 80	<ul style="list-style-type: none"> - Removing of bumps and excessive material – screed floor cover - Grinding and cleaning – fresh concrete - Grinding – ABRASIV materials 	6
	Diamond grinding head DIA THERMO-RG 80	<ul style="list-style-type: none"> - Tenacious and thermo-elastic materials, such as paints, protective paints, elastic glue 	5-6
	Hard-metal grinding head: grinding wheel provided with hard-metal grits HW Grob-RG 80	<ul style="list-style-type: none"> - Removing of elastic protective coats on walls and flooring - Reduction of gypsum and cellular concrete - Removing of impurities – concrete floors - Removing of latex or oil paints – gypsum surface - Rough working 	3-5
	Diamond grinding head, ABRASIV disk with soldered diamond grains DIA UNI-RG 80	<ul style="list-style-type: none"> - Universal use, removal of paint from concrete, hard plasters, wood, removal of elastic glues, hard plasters, soft concrete 	5-6
	Hard-metal grinding head: grinding wheel provided with hard-metal grits HW Fein-RG 80	<ul style="list-style-type: none"> - Removing of elastic protective coats on walls and flooring - Reduction of gypsum and cellular concrete - Removing of impurities – concrete surface - Removing of latex or oil paints on gypsum surface - Fein working 	3-5